



SPECIFIKACE MANIPULÁTORU

Název stroje:	MANITOU MRT 2150
Typ:	teleskopický
Interní kód:	UNC 30
Výška - složený (mm):	3050
Šířka - složený (mm):	2430
Délka - složený (mm):	6780
Světlá výška (mm):	370
Hmotnost (kg):	16 500
Výkon motoru (kW):	110
Kapacita palivové nádrže (l):	230
Kapacita hydraulické nádrže (l):	200
Kola:	18 - 22,5
Maximální nosnost nákladu (kg): (ve vzdálenosti 500 mm od pat vidlic)	4999 (na stabilizátorech)
Maximální výška zdvihu (m):	20,6

MANISCOPIC

MRT 2150

PRIVILEGE



- Lift height : 20.60 m
- Max. reach : 18.10 m
- Engine : 150 HP - 110 kw
- 4 wheel drive - 4 wheel steer
- Hydrostatic transmission
- Levelling system

 **MANITOU**

ROTATION ON STABILISERS FULLY EXTENDED WITH EXTENSIBLE PLATFORM 2,25/4 m

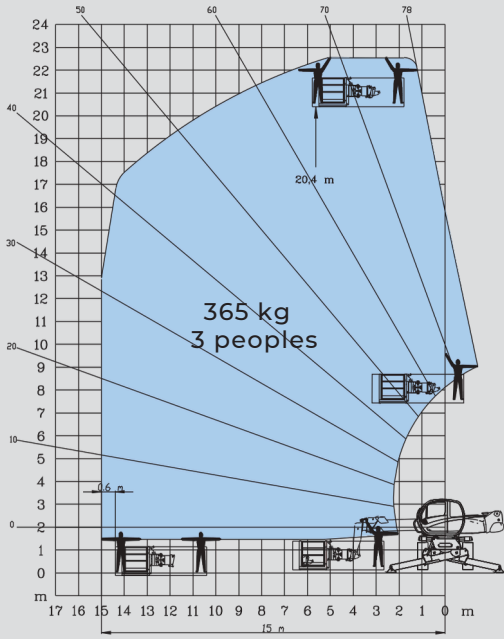

ROTATION ON STABILISERS FULLY EXTENDED WITH 1000 KG PLATFORM 2,25/4m

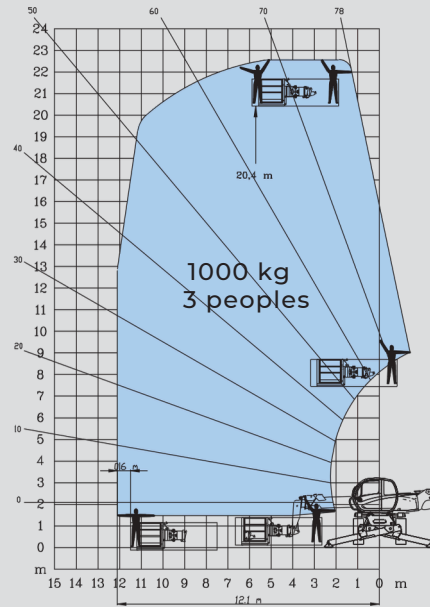

ROTATION ON STABILISERS FULLY EXTENDED WITH 3 D SYSTEM IN POSITIVE POSITION

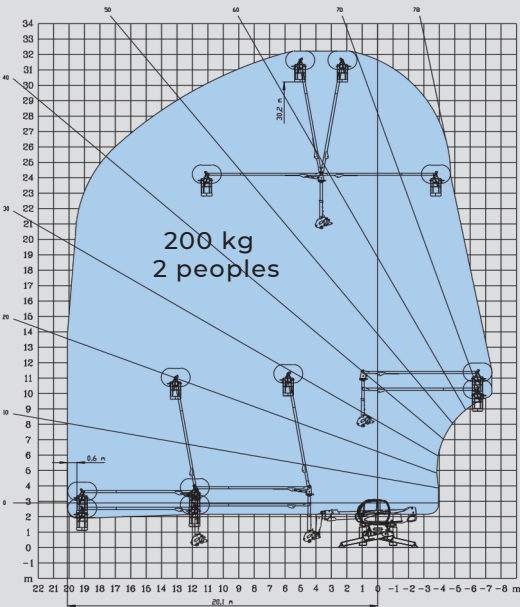

ROTATION ON STABILISERS FULLY EXTENDED WITH 3 D SYSTEM IN NEGATIVE POSITION

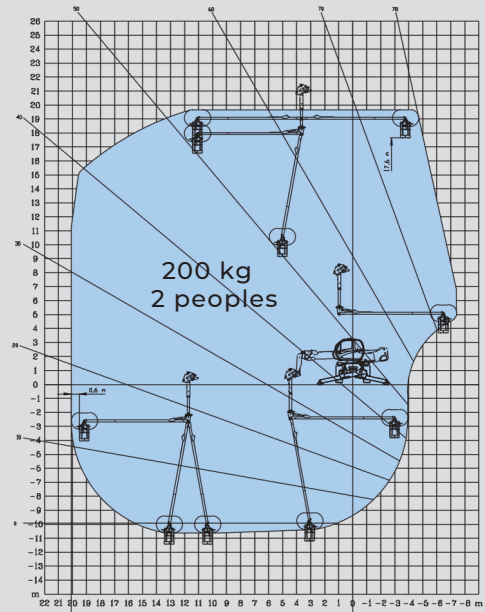

ROTATION ON STABILISERS FULLY EXTENDED WITH AERIAL JIB PLATFORM

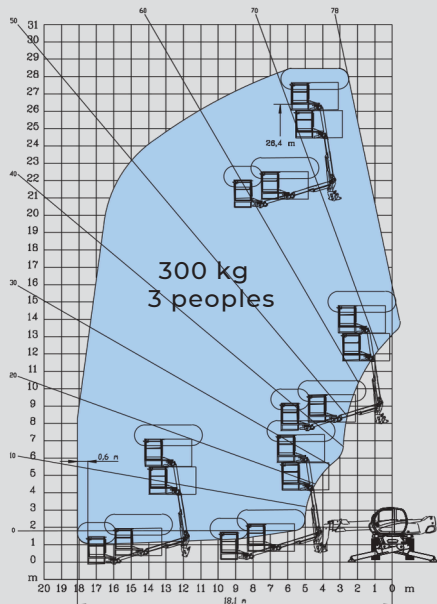

ROTATION ON STABILISERS FULLY EXTENDED WITH CRANE JIB

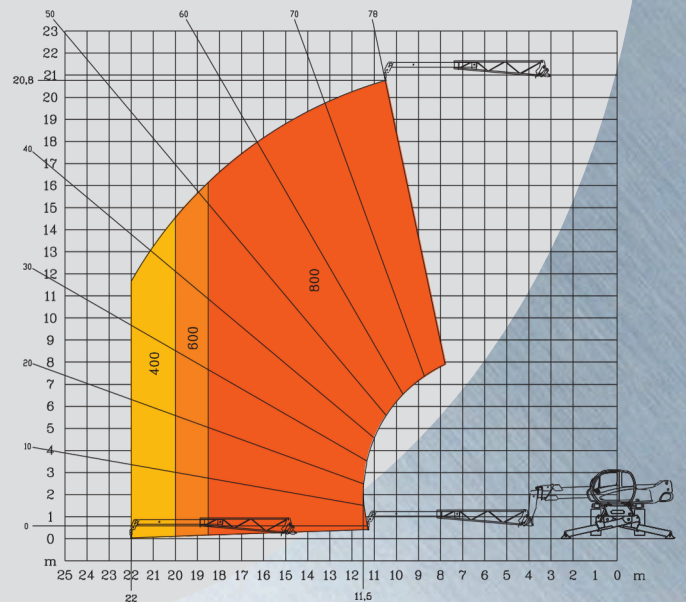

MRT 2150 **PRIVILEGE**

Lift capacity (on stabilisers)4999 kg
at 500 mm from forks heels



Lift height :20.60 m



Tyres
18 - 22,5



Forks (mm)
Length1200
Width x thickness150 X 50



Multidisc brakes : hydraulically assisted on both axles
Negative parking brake



Engine Mercedes-Benz
TypeOM 904 LA (EURO 3
Capacity4 cyl. 4250 cm³
Power (ISO/TR 14396)150 HP/110 kw
580 Nm of 1200 at 1600 rpm
Water cooling
Direct injection



Transmissionhydrostatic
With automatic power regulation (hydraulic variable displacement pump and motor)
Reversing shiftelectromagnetic
2 speed forward and reverse
Travel speed36 km/h*
*This speed may be limited by local regulations



Rear axle
Frame levelling on front axle +/- 8° (15%)
Automatic rear axle locking system
over 15° rotation



4 stabilizers
simultaneous or individually controlled



Total and continuous rotation
Turret mounted on a double slew ring
Hydraulic and electric rotation



Hydraulics
3 pumps gear type270 bars/160 l/mn



Control : 2 electro proportional control joysticks for all hydraulic movements



Capacities
Cooling system18 l.
Engine oil15 l.
Hydraulic oil200 l.
Fuel tank230 l.



Weight unladen (with forks)16095 kg
Overall width2.43 m
Overall height3.05 m
Overall length6.78 m
Ground clearance0.37 m
Drawbar pull8200 daN



Standard load moment indicator
(mobile crane standards)

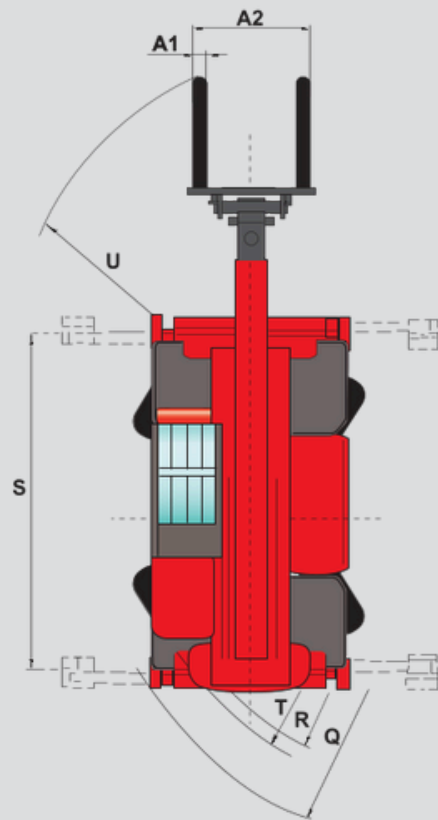
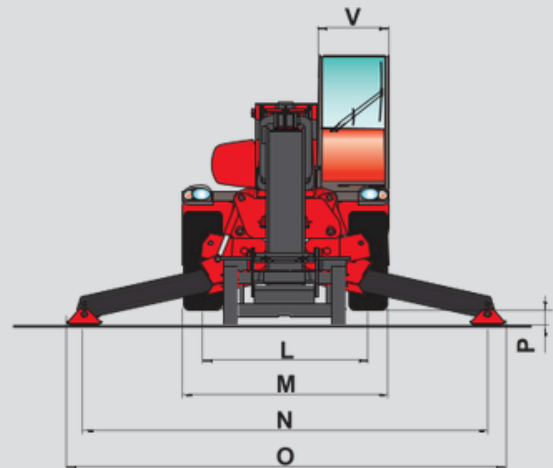
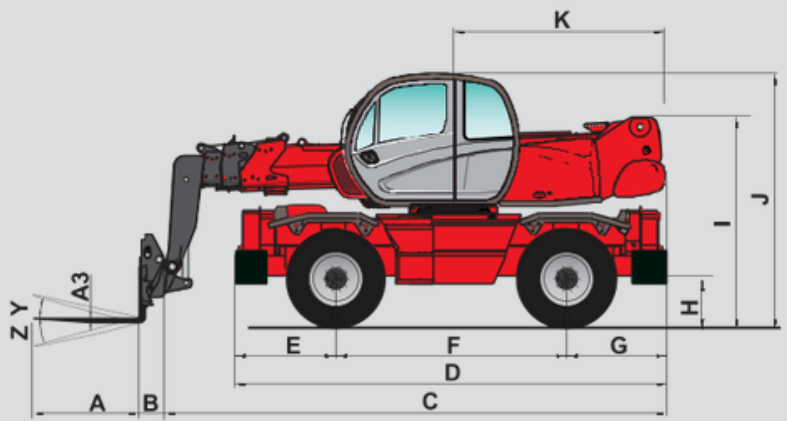

A	1200
A1	150
A2	1320
A3	50
B	290
C	6490
D	5050
E	1155
F	2750
G	1155
H	380
I	2485
J	3050
K	2485
L	1930
M	2425
N	4700
O	5100
P	150
Q	4500
R	3800
S	4550
T	4040
U	6230
V	950
Y	12°
Z	105°

This publication in no way constitutes an offer and the company reserves the right to alter specifications without prior notice.
The MANITOU models presented in this brochure can be supplied complete with optional equipment attachments.

